

**OPERATION AND MAINTENANCE INSTRUCTIONS  
WITH ILLUSTRATED PARTS BREAKDOWN**

**TEST SET, RADIO FREQUENCY  
MODEL 4410-030**

**NSN 6625-01-217-5631**

Bird Electronic Corporation  
30303 Aurora Road  
Cleveland (Solon), Ohio 44139

Contract No. M00027-85-C-0045

---

**1 JULY 1985**

## TABLE OF CONTENTS

| Chapter/Para                                      | Page |
|---|------|
| 1 INTRODUCTION . . . . .                          | 1-1  |
| 1-1. Purpose and Function . . . . .               | 1-1  |
| 1-2. Capabilities . . . . .                       | 1-1  |
| 1-3. Performance Characteristics . . . . .        | 1-1  |
| 1-4. Description . . . . .                        | 1-1  |
| 2 INSTALLATION . . . . .                          | 2-1  |
| 2-1. General . . . . .                            | 2-1  |
| 2-2. Unpacking . . . . .                          | 2-1  |
| 2-3. Connections . . . . .                        | 2-2  |
| 2-4. Installation of Load Resistor . . . . .      | 2-2  |
| 3 THEORY OF OPERATION . . . . .                   | 3-1  |
| 3-1. General . . . . .                            | 3-1  |
| 3-2. Wattmeter . . . . .                          | 3-1  |
| 3-3. Coupling Circuit . . . . .                   | 3-1  |
| 3-4. Reflected Power Readings . . . . .           | 3-1  |
| 3-5. Load Resistor . . . . .                      | 3-2  |
| 3-6. Variable Sampler Assembly . . . . .          | 3-2  |
| 4 OPERATING INSTRUCTIONS . . . . .                | 4-1  |
| 4-1. General . . . . .                            | 4-1  |
| 4-2. Frequency Range . . . . .                    | 4-1  |
| 4-3. Power Range Coverage . . . . .               | 4-2  |
| 4-4. Load Power . . . . .                         | 4-2  |
| 4-5. Determining VSWR . . . . .                   | 4-2  |
| 4-6. Shutdown . . . . .                           | 4-3  |
| 4-7. Performance . . . . .                        | 4-5  |
| 5 MAINTENANCE INSTRUCTIONS . . . . .              | 5-1  |
| 5-1. Preventive Maintenance . . . . .             | 5-1  |
| 5-2. Troubleshooting . . . . .                    | 5-2  |
| 5-3. Periodic Inspection . . . . .                | 5-3  |
| 5-4. Meter Replacement . . . . .                  | 5-3  |
| 5-5. Adjustment . . . . .                         | 5-5  |
| 5-6. Calibration . . . . .                        | 5-5  |
| 5-7. Instrumentation Module Replacement . . . . . | 5-5  |
| 5-8. Calibration and Test Procedure . . . . .     | 5-7  |

TABLE OF CONTENTS - Continued

| Chapter/Para                              | Page |
|---|------|
| 6 PREPARATION FOR RESHIPMENT . . . . .    | 6-1  |
| 6-1. Preparation for Reshipment . . . . . | 6-1  |
| 6-2. Storage Instructions . . . . .       | 6-1  |
| 7 PARTS LIST . . . . .                    | 7-1  |
| 7-1. General . . . . .                    | 7-1  |
| 7-2. Parts Illustration . . . . .         | 7-1  |
| 7-3. Parts List . . . . .                 | 7-1  |
| 7-4. Explanation of Columns . . . . .     | 7-1  |

## LIST OF ILLUSTRATIONS

| Figure | Title  | Page |
|--------|--|------|
| 1-1.   | Model 4410-030 Test Set . . . . .                          | 1-0  |
| 2-1.   | Wattmeter . . . . .  | 2-1  |
| 3-1.   | Schematic Diagram . . . . .                                | 3-2  |
| 4-1.   | VSWR Conversion Nomograph . . . . .                        | 4-3  |
| 4-2.   | VSWR Conversion Nomograph . . . . .                        | 4-4  |
| 5-1.   | Meter Replacement . . . . .                                | 5-4  |
| 5-2.   | Instrumentation Module Replacement . . . . .               | 5-6  |
| 5-3.   | Calibration Setup . . . . .                                | 5-9  |
| 5-4.   | Calibration Potentiometers . . . . .                       | 5-11 |
| 7-1.   | Test Set, Exploded View . . . . .                          | 7-4  |
| 7-2.   | Wattmeter Assembly, Exploded View . . . . .                | 7-6  |
| 7-3.   | Printed Circuit Board Assembly, Exploded View . . . . .    | 7-10 |
| 7-4.   | Printed Circuit Board Subassembly, Exploded View . . . . . | 7-12 |

## LIST OF TABLES

| Number | Title                              | Page |
|--------|------------------------------------|------|
| 1-1    | Table of Specifications . . . . .  | 1-2  |
| 5-1    | Troubleshooting . . . . .          | 5-2  |
| 5-2    | Wattmeter Test Equipment . . . . . | 5-7  |
| 5-3    | Calibration Table . . . . .        | 5-10 |

## SAFETY SUMMARY

The following are general safety precautions that are not related to any specific procedures and therefore do not appear elsewhere in this publication. These are recommended precautions that personnel must understand and apply during many phases of operation and maintenance.

### OPERATE EQUIPMENT SAFELY

During operation do not exceed the power rating of the test set. Dangerous potentials may exist when RF energy is excessive.

### KEEP AWAY FROM LIVE POWER

Do not replace components or attempt to disconnect the load from the transmission line while RF power is being applied. RF energy is a potential health hazard.

The following warnings and cautions appear in the text in this volume, and are repeated here for emphasis:

## WARNING

Exposure to RF power radiation and the possibility of RF shock or burns is possible with some operating conditions. Always be sure to turn off transmitter when connecting or disconnecting wattmeter. Be sure transmission line is terminated into a load or antenna. When the element is removed from the RF line socket, the line section center conductor is exposed. Do not put fingers or other objects into the element socket when RF power is on. (Page 4-1.)

When using the wattmeter, observe all safety precautions which apply to the equipment being tested. (Page 4-1.)

Do not exceed the power rating of the wattmeter. (Page 4-2.)

Never attempt to disconnect the load from the transmission line while RF power is being applied. Leaking RF energy is a potential health hazard. (Page 4-3.)

Provide adequate ventilation and observe normal precautions when using dry cleaning solvents. Many dry cleaning agents emit toxic fumes that may be harmful to your health if inhaled. (Page 5-1.)

Do not attempt to remove the resistive element from the load. Potentially toxic materials are used in its construction. (Page 5-3.)

**CAUTION**

Carefully check the condition of all cables and connectors before using the test set. (Page 1-3.)

Do not drop the wattmeter or its elements or subject them to hard blows. The microammeter is shock mounted in the wattmeter housing, but its delicate mechanism may be damaged by severe impact. (Pages 2-1 and 4-1.)

Do not operate these RF loads continuously above their maximum power ratings. Load failure will result. (Page 2-2.)

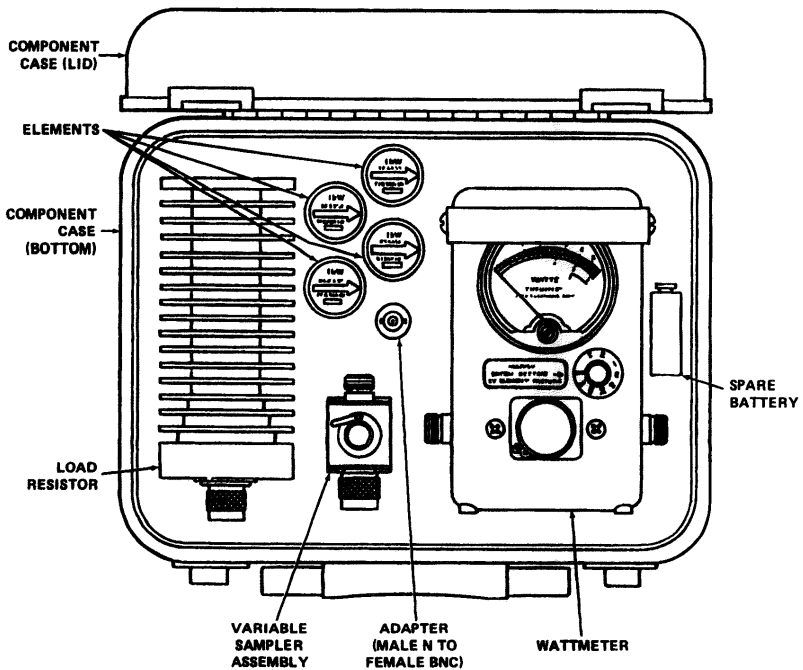

**NOTE: VSWR CHART AND TWO CABLE ASSEMBLIES ARE CONTAINED IN THE LID OF THE COMPONENT CASE.**

**Figure 1-1. Model 4410-030 Test Set**

## CHAPTER 1

## INTRODUCTION

1-1. PURPOSE AND FUNCTION. The Model 4410-030 Test Set uses an insertion type battery operated, Model 4410A RF Wattmeter, designed to measure power flow and load match in 50-ohm RF coaxial transmission lines. It is designed and intended for use on CW unmodulated or FM signals only.

1-2. CAPABILITIES. The Model 4410-030, when used in 50-ohm applications with N-type connectors, has an insertion VSWR of less than 1.05:1 up to a frequency of 1000 MHz. Included in the Test Set is a Model 8164-040 50-ohm load resistor used as an alternate line termination or antenna. Also included in the Test Set is a Model 4275-020 in-line variable radio frequency sampler which provides a minimum 30 dB reduction in radio frequency power at the sample port.

1-3. PERFORMANCE CHARACTERISTICS. The power ranges used are determined by the elements, which fall in frequency band groups.

1-4. DESCRIPTION. The Model 4410-030 Test Set (figure 1-1) is a portable unit contained in a carrying case. The test set consists of a wattmeter, terminal load resistor, VSWR chart, two cable assemblies, four elements, adapter, spare battery, and variable sampler assembly.

a. The Model 4410-030 Test Set is a portable unit contained in a die cast aluminum housing, with a formed metal enclosure on the back which is easily removed. Included with the unit is a leather carrying strap, four rubber shock feet on the base, and four rubber bumpers on the back, which allow the Model 4410A Wattmeter to stand or lie flat when used. For additional protection, the microammeter is shock mounted. A slotted screw is provided on the lower front face of the meter for zeroing the pointer.

(1) The meter has two scales, a 0 to 1 scale and a 0 to 3 scale. Power is read in multiples of the values indicated by the pointer. Below the meter, the RF line section face protrudes slightly from the wattmeter housing with the plug-in socket in the center. The silver plated brass RF line section provides the best possible impedance match to the coaxial RF transmission line in which the Model 4410A is inserted. At each end of the line section are quick-change type RF connectors, which may be quickly interchanged with other QC connectors.

(2) A battery access panel is located on the back of the case to allow the operator to change batteries.

(3) To make measurements, the cylindrical shaped element is inserted into the line section socket and rotated against one stop. A small catch in the lower left hand corner of the casting face presses on the shoulder of the element to keep it in proper alignment and assure a good contact with the lower edge of the element and line section body. See table 1-1 for wattmeter specifications.



Table 1-1. Table of Specifications

SPECIFICATIONS FOR MODEL 4410-030 TEST SET

Model 4410A Wattmeter

|                                   |   |
|-----------------------------------|---|
| Impedance . . . . .               | 50 ohms nominal   |
| Insertion VSWR . . . . .          | 1.05 maximum, 0-1GHz equipped with F-N connectors (32.3 dB return loss)   |
| Connectors . . . . .              | Bird Quick Change "QC" type Female N  |
| Over ranging . . . . .            | 120% of element power rating regardless of selector switch setting (Certain connector types limited to rating of connector) |
| Power and frequency range†        |   |
| 0-10,000W . . . . .               | .2-30 MHz   |
| 0-1,000W . . . . .                | 30-1000 MHz   |
| 0-100W . . . . .                  | 25-1000 MHz   |
| Accuracy* . . . . .               | ±5% of reading above 20% of full scale of selected power range  |
| Temperature range                 |   |
| Operating . . . . .               | 0° to 50°C (32° to 122°F)   |
| Storage . . . . .                 | -25° to 65°C (-13° to 149°F)  |
| Relative humidity range . . . . . | 5% to 90% noncondensing   |
| Dimensions . . . . .              | 3-3/8" L x 4" W x 6-7/8" H<br>(85.7 x 101.6 x 174.6mm)  |
| Weight . . . . .                  | 3 lbs. (1.4kg)  |
| Power requirement . . . . .       | 9V dc battery   |
| Battery life . . . . .            | 160 hours continuous use  |

Model 8164-040 Coaxial Load Resistor

|                              |                                    |
|------------------------------|------------------------------------|
| Impedance . . . . .          | 50 ohms nominal                    |
| Power rating . . . . .       | 100 watts continuous               |
| Frequency range . . . . .    | DC-1000 MHz                        |
| VSWR . . . . .               | 1.1 maximum DC to 1.0 GHz          |
| Input connector . . . . .    | Female N-Type                      |
| Dimensions (body) . . . . .  | 2-3/4" SQ x 6-1/4" LG (70 x 159mm) |
| Weight . . . . .             | 3 lbs. (1.4kg)                     |
| Operating position . . . . . | Any                                |

Model 4275 Variable Sampler

|                           |                 |
|---------------------------|-----------------|
| Impedance . . . . .       | 50 ohms nominal |
| Maximum power . . . . .   | 1000 watts      |
| Frequency range . . . . . | 2-1000 MHz      |

† Power and frequency range is determined by 4410 type plug-in elements used.

\* Exception - Element P/N 4410-1 0.200-0.535 MHz has an accuracy of ±10% of reading.

Table 1-1. Table of Specifications - Continued

|                  |                                |
|------------------|--------------------------------|
| Insertion VSWR   | 1.1 maximum 2-512 MHz**        |
| In 50 ohm system | 1.25 maximum 512-1000 MHz      |
| Insertion loss   | 0.1 dB maximum 2-512 MHz**     |
|                  | 0.2 dB maximum 512-1000 MHz    |
| Coupling         | Adjustable as shown $\pm 2$ dB |
| Connectors       | Bird Quick Change "QC" type    |
| Dimensions       | 2-51/64"L x 2-7/8"W x 1-1/4"H  |
|                  | (71.0 x 73.0 x 31.7mm)         |
| Weight           | 10 oz (.28kg)                  |

\*\* With N connectors.

b. The Model 8164-040 Load Resistor is a self contained unit, liquid free, and air cooled. It provides accurate and practically nonreflective terminations for testing and adjusting transmitter under nonradiating conditions. This is used for the following purposes:

- (1) As a substitute antenna.
  - (a) For turning RF transmitters under nonradiating conditions.
  - (b) For making routine tests and adjustments.
- (2) As a substitute for any circuit loading element.
- (3) To measure, with a suitable indicating device, the power output of any coaxially transmitted RF signal within its rating.

The load resistor is provided with rubber bumpers on the base and on the side to allow operation of the load resistor and test meter in the same plane.

c. The Model 4275-020 Variable Frequency Sampler provides in-line operation and a sample signal. The coupling factor is variable by the operator and has a locking feature.

**CAUTION**

Carefully check the condition of all cables and connectors before using the test set.

d. Furnished with the Test Set are cable assemblies Model 4410-038-1, RG 142 B/U (1) and Model 4410-037-1, RG 58/U (2) used with a 5-798-1, UG 201 connector to provide in-line test setup.



CHAPTER 2  
INSTALLATION

2-1. GENERAL. The wattmeter is essentially a portable test instrument and should be placed as close as possible to the equipment whose power is being measured. Use this wattmeter in an upright or lying down position.

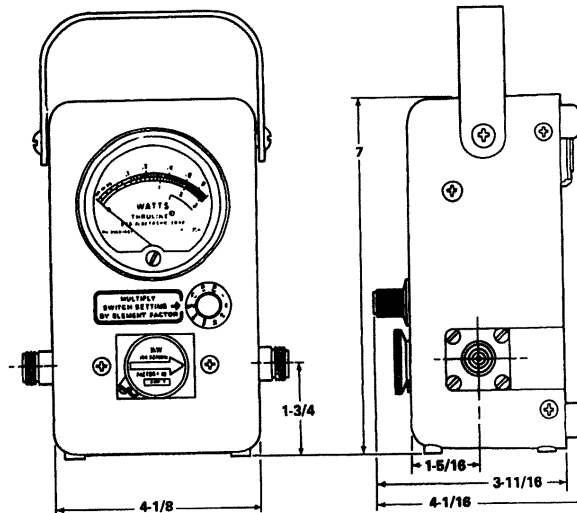

Figure 2-1. Wattmeter

**CAUTION**

Do not drop the wattmeter or its elements or subject them to hard blows. The microammeter is shock mounted in the wattmeter housing, but its delicate mechanism may be damaged by severe impact.

2-2. UNPACKING. Open the carrying case and ensure that all components are present. Visually inspect all components for any damage they may have occurred during shipping or transporting.

NOTE

When transporting the test set, be sure the range switch on the wattmeter is in the off position. In any other switch position there is a slight drain on the 9V battery. If the unit is to be inactive for an appreciable amount of time, it is good practice to remove the battery to avoid damage from possible battery leakage. Handle the plug-in elements with care at all times. Calibration could be disturbed if they are dropped or subjected to hard blows.

2-3. CONNECTIONS.

a. Insert the wattmeter in coaxial transmission lines of 50 ohms nominal impedance. It is indifferent to which respective side the power source and the load connections are made. If cables other than 50 ohms are used, a mismatch will occur causing probable serious inaccuracies in readings. However, if a mismatch cannot be avoided, the results may be calculated per Chapter 4.

b. The wattmeter is supplied with two female N-type connectors which are of the quick-change design.

2-4. INSTALLATION OF LOAD RESISTOR.

a. Allow at least six inches of clearance around the load resistor to permit an unimpeded access of convection air currents for adequate heat dissipation. Place the RF loads to permit the shortest possible cable length between the units and the transmitting equipment.

**CAUTION**

Do not operate these RF loads continuously above their maximum power ratings. Load failure will result.

b. These RF loads may be used for portable operation or fixed installation. The load resistor is light enough to be attached directly to the mating RF connector of another device such as a wattmeter or set on the workbench. Attach the load resistor as close as possible to the transmitter's output and use only suitable connectors. Try to connect direct to minimize cable length and avoid the use of adapters as much as possible.

## CHAPTER 3

## THEORY OF OPERATION

3-1. GENERAL. The Model 4410-030 Test Set is designed to measure, terminate, and sample RF power. The test set will accurately and precisely measure power through the use of the Model 4410A Wattmeter. The load resistor will terminate the coaxial line and take the place of an antenna. The variable sampler assembly provides the ability to sample the RF power for use with an oscilloscope or frequency counter. On any uniform RF line section there are voltages, currents and standing waves present when RF power is applied. These are the results of two traveling waves, forward and reflected. The characteristic impedance of these lines is a pure resistance, usually 50 ohms, for useful lines.

3-2. WATTMETER. The main RF component of the wattmeter is a short piece of uniform air type line section whose characteristic impedance is a very accurate 50 ohms, in which correct measurements may be made.

3-3. COUPLING CIRCUIT. The coupling circuit which samples the traveling waves is in the element. The circuitry of the element and its relationship to the other components of the wattmeter are illustrated in figure 3-1. Energy will be absorbed in the coupling circuit of the element both by mutual inductance and capacitance from the traveling RF waves of the line section. The inductive currents within the line section will flow according to the direction of the traveling waves producing them. The capacitive portion of these currents is independent of the traveling waves. It is, therefore, apparent that the current produced from the waves traveling in one direction will add in phase, while the current produced from the waves traveling in the opposite direction will subtract in phase. The ARROW on the element indicates the additive direction of wave travel. The element is so designed that the wave components traveling in the opposite direction of the ARROW will cancel each other out almost completely, making the element highly insensitive to the reverse wave direction. This signal which is to be measured, is detected and through the use of a self-balancing bridge circuit, an accurate power reading is obtained. The non-linearity and temperature instabilities of the detector diode are avoided by using a secondary balancing detector diode connected in opposition to the principal detector diode. These two diodes are selected for similar characteristics so they are nearly identical and diode variables are virtually eliminated. Also, the two diodes are mounted close to each other in the same enclosure and subjected to the same thermal environment almost eliminating thermal effects. Because of the highly directional characteristics of the element, the resultant direct current which is sensed by the microammeter indicates the power level of only the RF waves traveling in the ARROW direction.

3-4. REFLECTED POWER READINGS. The element is designed so that it can be rotated 180° in its socket in the line section. When it is rotated, the meter will indicate the power in a direction opposite that of the initial reading, so that if the forward direction power was read first, then the reflected direction power will be read after the element is rotated. The energy resulting from the inductively coupled component of the forward wave will bring about cancellation as described above.

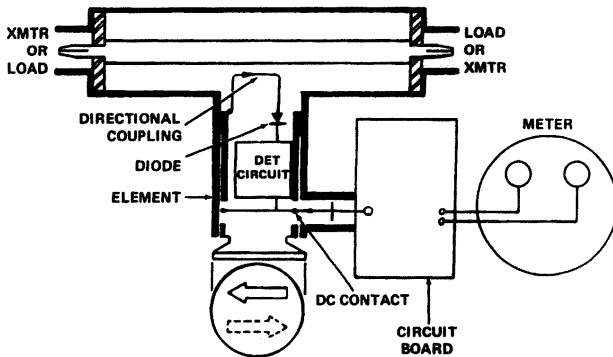

Figure 3-1. Schematic Diagram

3-5. **LOAD RESISTOR.** The resistive element of the load resistor is individually selected for its accuracy and film uniformity. It is enclosed in a specially tapered heat sink housing. This special contour along with the resistive element provides the unusually low power reflection characteristics over the entire frequency range. The resistor along with the taper of the housing provide a reduction in surge impedance proportional to the distance along the length of the resistor. The characteristic impedance is therefore 50 ohms at the front, or input connector, and diminishes to zero ohms at the rear where the resistor is terminated to the heat sink housing that provides the return conductor of the coaxial circuit.

3-6. **VARIABLE SAMPLER ASSEMBLY.** The Variable Sampler Assembly has one female and one male N-type connector for insertion in the line, and one female BNC type connector for the sample signal output. It makes no difference which way the sampler is inserted in the coaxial line. A small amount of the RF power is picked off by a variable capacitive probe. The amount of sampled RF power is regulated by increasing or decreasing the amount of capacitive coupling. The adjustment control is on the opposite side of the BNC output connector.

## CHAPTER 4

### OPERATING INSTRUCTIONS

4-1. GENERAL. Measurements are made by the insertion of the elements furnished with each test set.

#### WARNING

Exposure to RF power radiation and the possibility of RF shock or burns is possible with some operating conditions. Always be sure to turn off transmitter when connecting or disconnecting wattmeter. Be sure transmission line is terminated into a load or antenna. When the element is removed from the RF line socket, the line section center conductor is exposed. Do not put fingers or other objects into the element socket when RF power is on.

When using the wattmeter, observe all safety precautions which apply to the equipment being tested.

#### CAUTION

Do not drop the wattmeter or its elements or subject them to hard blows. The microammeter is shock mounted in the wattmeter housing, but its delicate mechanism may be damaged by severe impact.

a. With the element inserted in the line section receptacle, forward power is indicated when the ARROW on the element plate points in the direction of power flow; i.e., from transmitter to load. Reflected power measurements are made with the element rotated 180° with the ARROW on the plate pointing toward the transmitter. When power measurements are being made, make sure the element is rotated fully so that the index pin protruding from the element's cylindrically shaped body rests against the stop on the line section, either in the forward or reflected position. Also ensure that the small catch in the lower left hand corner of the casting face presses on the shoulder of the element to keep it in proper alignment and assure a good contact between the lower edge of the element and line section body.

b. Before any power measurements are made, ensure the pointer rests on the zero mark. If it is not, adjust the zero adjustment screw, with the range switch in the OFF position, clockwise (cw) or counterclockwise (ccw) until the pointer rests at the zero mark. This adjusting screw is located at the bottom center of the meter bezel face.

4-2. FREQUENCY RANGE. The elements are selected for the frequency range being used.



|                |
|----------------|
| <b>WARNING</b> |
|----------------|

Do not exceed the power rating of the wattmeter.

4-3. **POWER RANGE COVERAGE.** Each element is marked with its maximum power range capability, usually 1 kW or 10 kW. Also stamped on the element nameplate is a factor number. The power range switch on the wattmeter determines the full scale power range to be used. This switch when set on a numbered position and multiplied by the element factor number, gives the full scale power value. For example, if the element factor is 10 and a switch setting of 30 is opposite the ARROW on the front face of the unit, 30 multiplied by 10 gives you 300 W. This is the full scale value the unit is to be used. In this case the lower scale on the meter face will be used. If the number opposite the ARROW is 10 and the element factor is 10, thus  $10 \times 10 = 100$ , and 100 W will be the full scale reading and the upper scale will be used. For reflected power readings the element is rotated  $180^\circ$  in the element socket and the same system is used, however, a much lower switch setting maybe advantageous for better resolution.

4-4. **LOAD POWER.** Where appreciable power is reflected, as with an antenna, it is necessary to subtract the reflected from forward power to obtain load power. Power delivered to and dissipated in an antenna is given by:

$$W_l = W_f - W_r$$

Where:  $W_l$  = power into load

$W_f$  = forward power

$W_r$  = reflected power

This correction is negligible, less than 1% if the load is such as to have a VSWR of 1.2 or less.

#### NOTE

The wattmeter used with a load resistor of proper power rating forms a highly useful absorption wattmeter. Since the reflected power will be negligible, it will be unnecessary to rotate the element from the forward direction.

4-5. **DETERMINING VSWR.** The wattmeter is not designed to provide direct VSWR readings. However, VSWR readings can be determined very easily by the use of the provided graphs as follows:

- a. Determine the forward and reflected power as described above.
- b. Refer to the appropriate graph, figure 4-1 or 4-2, to convert the forward and reflected power readings to VSWR. Note that the graphs convert the readings directly to VSWR without any intermediate computations.

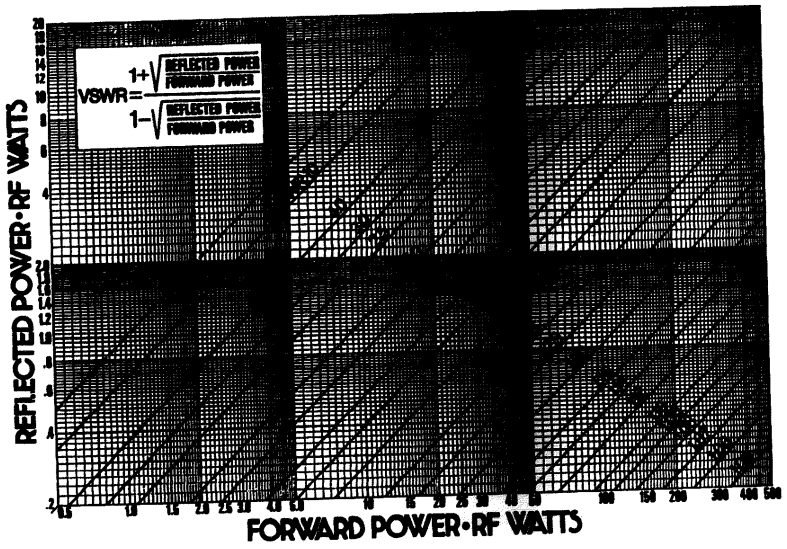

Figure 4-1. VSWR Conversion Nomograph

**WARNING**

Never attempt to disconnect the load from the transmission line while RF power is being applied. Leaking RF energy is a potential health hazard.

4-6. SHUTDOWN. When all measurements are completed, be sure to turn the power range switch to the OFF position. Leaving the switch on one of the power ranges will

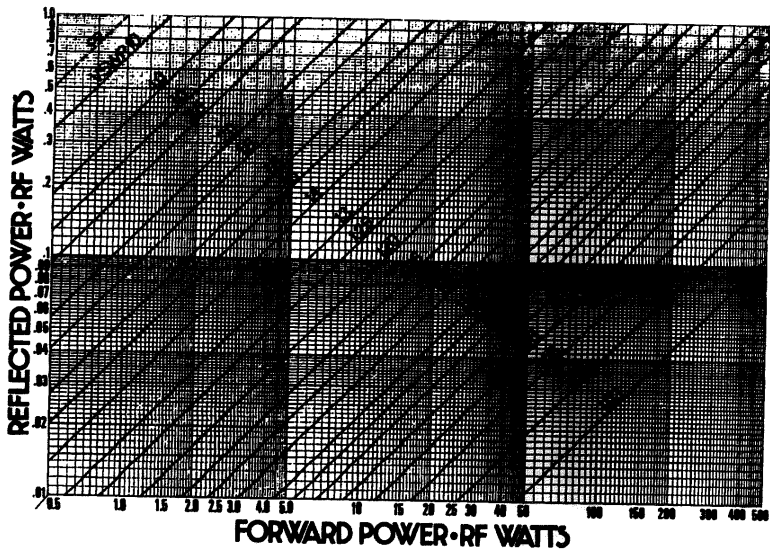

Figure 4-2. VSWR Conversion Nomograph

not be detrimental to the circuit in any way other than the fact that it will shorten battery life.

**NOTE**

There is a battery test position on the range selector switch. This battery test position is provided to conveniently check the condition of the battery occasionally to assure accuracy of the unit.

4-7. PERFORMANCE. The wattmeter is sensitive to a modulated signal which effects the accuracy. However, small amounts of AM (up to 10 percent) are tolerable, but for every 1 percent of AM the reading may increase up to 1 percent beyond the rated accuracy. Use above 10 percent AM is not recommended.

a. The stated accuracy does not include effect of less than infinite directivity of the element used. This is generally insignificant except for reflected power measurements where VSWR is low.

b. Although the wattmeter is equipped with quick-change connector types, it must be remembered that the power rating and insertion loss may be affected if other than the N-type connectors are used. Power limits must be governed by the type of connector or transmission line used.

c. The accuracy of the unit may be affected by a weak battery. Check the condition of the battery occasionally by use of the battery test position on the selector switch. If the pointer on the meter indicates below the battery test zone, it must be replaced.

d. When the range switch of the wattmeter is set in one of the numbered positions; i.e., other than OFF or BAT, it is normal for the meter to drift or deviate off the zero setting. This condition occurs when an element is out of the line section socket or if the element is rotated 90° in the line section in a shorting position.



CHAPTER 5  
MAINTENANCE INSTRUCTIONS

5-1. PREVENTIVE MAINTENANCE. This test set requires only simple and routine maintenance.

- a. Avoid subjecting the wattmeter to rough treatment.
- b. Keep the connectors and air line covered when wattmeter is not in use. This will prevent dust and dirt from accumulating in the connectors and air line.
- c. Wipe off dust and dirt regularly.

**WARNING**

Provide adequate ventilation and observe normal precautions when using dry cleaning solvents. Many dry cleaning agents emit toxic fumes that may be harmful to your health if inhaled.

- d. All contacts must be kept clean to assure low resistance connections to and within the unit.

- e. RF Connectors - Clean RF connectors with a cotton swab stick dampened with alcohol, freon or any acceptable dry cleaning solvent.

- f. Clean the inside of the line section socket bore and the entire circumference of the element with a cotton swab stick dampened with dry cleaning solvent. Pay particular attention to the cleaning of the bottom rim of the element body and to the seat of the socket in the line section. Check the inside of the line section for dirt and contamination. Clean the reachable portions of the line section with a cotton swab stick. Blow out the remaining dirt with low pressure, dry compressed air. Do not attempt to remove the RF line conductor from the line section. Any attempt to remove it will ruin the assembly.

- g. Clean the meter and meter housing using a cloth dampened with a mild detergent solution. Do this only when necessary and take care not to allow water to enter any of its circuitry as damage may result.

- h. To replace the battery, pry open the battery compartment cover. Use your fingernail, coin, or any other flat object to snap open the cover from the left or ribbed side. Manipulate the battery out of the compartment, a small screwdriver or knife may be useful for this purpose.

- i. When the battery is free, remove the snap-on battery plug and replace battery with a fresh one. When reinserting the battery in its compartment, feed the connecting wires through the hole in the back of the compartment to provide room for the battery.

NOTE

Correct polarity is automatically obtained when installing battery. The battery and wire lead connectors are matched to be installed for correct polarity.

5-2. TROUBLESHOOTING. Refer to table 5-1 for a listing of troubles that might occur during operation of the test set and load resistor. Possible causes and remedies are also listed.

Table 5-1. Troubleshooting

| Trouble  | Possible cause   | Remedy  |
|--|--|---|
| No meter indication                            | No radio frequency power                                   | Check transmitter and refer to operating instructions for equipment used. |
|  | Arrow on element pointing in wrong direction               | Rotate element so that arrow points in direction of power flow.           |
|  | Open or short circuit in meter cable assembly              | Replace defective cable.  |
|  | Meter burned out or damaged                                | Replace meter.  |
| Intermittent or inconsistent meter readings    | Faulty transmission line or load                           | Inspect line connections, antenna or load.                                |
|  | Faulty transmission line                                   | Replace transmission line.  |
|  | Dirty elements   | Clean elements.   |
|  | Sticky or defective meter                                  | Replace meter.  |
| High VSWR or high percent reflected power      | Bad load or poor connectors                                | Replace load, antenna or connectors.                                      |
|  | Shorted or open transmission line                          | Replace transmission line.  |
|  | Foreign material in line section or in RF connector bodies | Check for foreign material and clean as required.                         |
| Excessive overheating of load resistor         | Transmitter power too high                                 | Reduce transmitter power.   |
|  | Faulty RF resistor   | Replace load resistor.  |
| High or low resistance values of load resistor | Loose QC connector   | Tighten with a screwdriver.   |
|  | Faulty RF resistor   | Replace load resistor.  |

5-3. PERIODIC INSPECTION. This test set is ruggedly constructed and will normally provide trouble-free service. Periodic inspections should be performed at six-month intervals. Check for:

- a. Inspect wattmeter for cracked meter lens.
- b. Inspect wattmeter for damaged or missing latch and pivot pin assembly.
- c. Inspect wattmeter for bent, broken, or missing pins in female N connectors.

**WARNING**

Do not attempt to remove the resistive element from the load. Potentially toxic materials are used in its construction.

- d. Inspect load resistor for completeness and general condition.
- e. Inspect variable frequency sampler for bent, broken, or missing pins in male, female N connectors and female BNC connector.
- f. Inspect cable assemblies for damaged connectors and frayed cable.

5-4. METER REPLACEMENT. The meter is a rugged instrument which is shock mounted in its housing. When properly used, this meter should function properly without breakdown. A defective meter cannot be repaired, replace as follows:

- a. Remove meter from wattmeter.
  - (1) Place the wattmeter assembly face down on a smooth, clean surface. Remove cover assembly.
  - (2) Remove four screws (1, figure 5-1) from side of wattmeter to remove cover assembly (2).
  - (3) Remove meter wires (3) from meter. Mark wires to facilitate assembly.
  - (4) Remove two screws (4) from housing (5) and shock mount (6).
  - (5) Remove meter (8), shock mount (6), shock strip (7), and three stem bumpers (9). Slide shock mount and shock strip off meter. Remove stem bumpers from meter.
- b. Install meter.
  - (1) Install stem bumpers (9), shock strip (7), and shock mount (6) on meter (8).
  - (2) Insert meter in housing (5).
  - (3) Align shock mount holes with holes in housing and install two screws (4). Use Loctite No. 23 on screw shanks.

NOTE

Before tightening screws, rotate meter to align meter face with opening in housing.



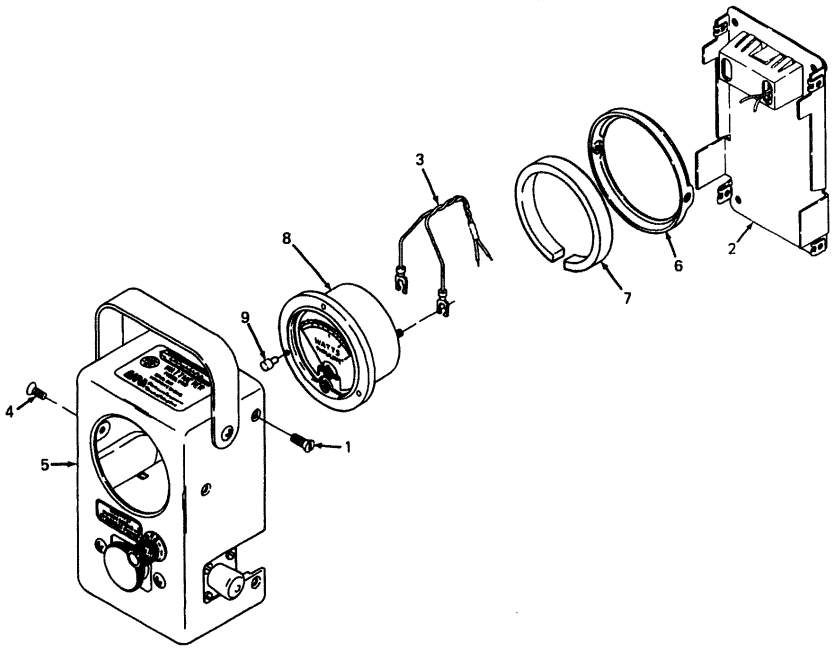

- 1. Screw
- 2. Cover assembly
- 3. Meter wire

- 4. Screw
- 5. Housing
- 6. Shock mount

- 7. Shock strip
- 8. Meter
- 9. Stem bumpers

Figure 5-1. Meter Replacement

- (4) Attach meter wires (3) to back of meter. Install washers and nuts to secure meter cable wires.

#### NOTE

Install orange wire on positive (+) terminal.

- (5) Install cover assembly (2) and secure with four screws (1).

5-5. ADJUSTMENT. The only adjustment on the wattmeter is to zero the meter. Before taking any readings, zero the meter pointer under no-power conditions by turning the slotted screw located on the lower front face of the meter.

5-6. CALIBRATION. Usually no calibration is required after meter replacement. Accuracy of the wattmeter can be determined by comparison with another wattmeter.

5-7. INSTRUMENTATION MODULE REPLACEMENT. The instrumentation module contains the line section and circuit board chassis as integral parts.

- a. Remove the instrumentation module from the wattmeter.

- (1) Remove the cover assembly as described in paragraph 5-4.
- (2) Remove two screws (1, figure 5-2) from the front of the wattmeter.
- (3) Remove servicing knob (2).
- (4) Unsolder meter wires (3) from capacitors (4) and lug (5). Matchmark wires to facilitate assembly.
- (5) Remove instrumentation module (6) from housing (7).

- b. Install instrumentation module.

- (1) Insert instrumentation module (6) into housing (7).
- (2) Solder meter wires (3) to capacitors. Red wire from battery is soldered to capacitor which is located closest to the front of the wattmeter. Orange wire from meter is soldered to capacitor which is located closest to the rear (cover assembly end) of the wattmeter. Solder both black wires to lug (5).
- (3) Install service knob (2).
- (4) Install two screws (1) through housing (7) and into instrumentation module.
- (5) Install cover assembly.



5-8. CALIBRATION AND TEST PROCEDURE. This procedure provides the complete calibration for the wattmeter should it become necessary.

a. Calibration of Wattmeter. Refer to table 5-2 for recommended equipment.

(1) Calibration equipment requirements.

- (a) The sine wave generator must be able to produce a stable 1000 Hz  $\pm 100$  Hz symmetrical sine wave at various output voltages between 0.05 and 1.6 volts RMS into an impedance of approximately 600 ohms resistive. Its output level adjustment must be such that these various specific output levels can be conveniently adjusted to within  $\pm 0.03$  percent of their stated value. Total harmonic distortion must be less than 0.2 percent.
- (b) The digital multimeter must have an ac voltmeter range capable of measuring the RMS voltage amplitude of the sine wave within  $\pm 0.1$  percent, with a resolution of at least 3-1/2 significant digits.
- (c) The element requires no adjustment. However, care should be taken to avoid damage to the unit from rough handling or exposure to voltages greater than those specified.
- (d) The field strength meter should be set on its maximum sensitivity when possible.
- (e) The work space must be free from electrical noise and radiated signals. The area in which the calibration is to be performed may be checked for spurious radiation with a Bird Model 43 Wattmeter equipped with a Model 4030 relative field strength element. Calibration should not be performed in areas where spurious radiation is present as indicated by any meter deflection on the Model 43/4030 combination. Be sure the gain on the Model 4030 is set at maximum.
- (f) The work space and equipment must be in a uniform and stabilized ambient temperature between 68° to 77°F (20° to 25°C).
- (g) The relative humidity of the work space must be no greater than 50% and must be non-condensing.

Table 5-2. Wattmeter Test Equipment

| Item | Qty | Type of unit required        | Recommendation  |
|------|-----|------------------------------|---|
| 1    | 1   | Sine wave generator          | Hewlett Packard Model 329A  |
| 2    | 1   | Precision digital multimeter | Data precision Model 3500   |
| 3    | 1   | Plug in calibration element  | Bird Model 4410-070   |
| 4    | 1   | Field strength meter         | Bird Model 43 equipped with<br>Bird Model 4030 relative<br>field strength element |
| 5    | 1   | BNC adapter tee              | Kings Connectors (UG274 A/U)  |

- (h) Allow all the equipment and the instrument to be calibrated to completely stabilize with respect to the environment of the work area (specified above). The Bird Model 4410 Instrument to be calibrated and the Bird Model 4410-070 calibration element may require up to 24 hours for complete environmental stabilization if brought from an extreme storage environment 149°F (65°C) 90% relative humidity into the work-space environment 68°F (20°C) 50% relative humidity. Remove the dust plug or any element from the 4410's line section during this environmental stabilization period.
- (2) Connect the sine wave generator and voltmeter to a BNC T adapter as shown in figure 5-3 with 50 ohm coaxial cables, such as RG 58/U, no more than three feet long (1 meter).
- (3) Calibration Procedure. With the wattmeter selector switch in the off position, carefully turn the zero adjust screw on the face of the meter for a zero setting. Using the BAT and OFF positions on the switch, repeat this process until a repeatable zero setting is obtained. The access holes for the calibration potentiometers, R25 (electrical zero adjust) and R26 (full scale calibration) are sealed with a protective label. This label, which is signed and dated showing the original calibration date, must not be disturbed until recalibration becomes necessary and certainly not within the warranty period. Disturbing this label voids the warranty. If the unit is to be field calibrated, after the warranty period, access to the calibration potentiometers, R25 and R26, is provided by piercing the protective label at the points shown by a circle with an x in it "⊗," see figure 5-4 for reference.
- (a) Connect the sine wave generator to the calibration element, Part No. 4410-070, and voltmeter as shown in figure 5-3.
- (b) Turn on the ac voltmeter and sine wave generator. Adjust the output to  $1.591 \pm 0.0005$  volts RMS at 1000 Hz  $\pm 100$  Hz. Make sure that the generator's "symmetry," "offset," and "waveform" controls are set to provide a symmetrical sine wave with zero dc offset. Leave the equipment in this condition to stabilize for the period of time recommended by the manufacturers but not less than five minutes.
- (c) Turn the 4410A on to its "100" position and allow it a minimum of five minutes to stabilize. The 4410A does not need to be connected to the calibration setup for the five minute warmup period.
- (d) After the equipment has stabilized, check the battery in the 4410A by momentarily placing its switch in the "BAT" position. The meter pointer should travel well into the "BATTERY TEST" region of the meter scale. If necessary, turn the unit off and replace the battery. Return the switch to the "100" position. Allow the unit's internal circuitry to stabilize for another five minutes if the battery was replaced.

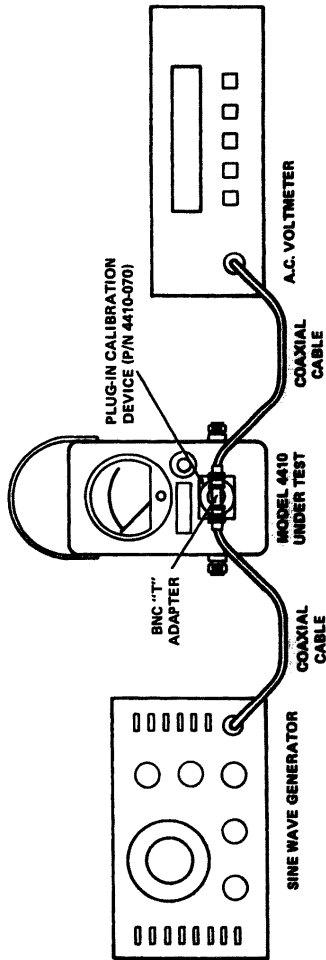

Figure 5-3. Calibration Setup

- (e) Insert the calibration element into the 4410A and rotate it in either direction until it stops.
- (f) Recheck the sine wave generator for the proper 1000 Hz  $\pm 100$  Hz output settings, then readjust the amplitude as necessary, until the voltmeter reads a stable 1.591  $\pm 0.0005$  volts.
- (g) Rotate the calibration element approximately 90° so as to short the contact in the socket to the line section body. If the meter needle does not come to rest at exactly zero, then adjust R25 counterclockwise, very slowly, just until it does. The location of R25 is shown in figure 5-4. If the pointer already rests at exactly zero, then go on to step (h).
- (h) Rotate the calibration element in either direction until it stops.
- (i) Adjust R26 until the meter pointer is at "1," full scale on the uppermost scale. The location of R26 is shown in figure 5-4.
- (j) Rotate the calibration element 90° so as to short circuit the spring contact in the socket to the line section body. Simultaneously measure the time required for the meter pointer to travel from its full scale position to zero. Adjust R25 and repeat steps (h) and (i) until the time required for the meter pointer to travel from a full scale reading to zero is 4.0  $\pm 1.0$  seconds.
- (k) Turn the calibration element 90° to short circuit the spring contact in the line section to the line section body. Set the 4410A range switch to the "1" position. Now adjust the sine wave generator's output to 0.1591  $\pm 0.00005$  volts RMS. Rotate the calibration element in either direction until it stops. Then adjust R26 until the meter pointer rests at "1" on the upper scale.
- (l) Check all of the other ranges by applying the proper voltages for each range in accordance with table 5-3. In each case, the meter pointer should come to rest at "1" on the upper scale, within the tolerance shown.

Table 5-3. Calibration Table

| Range | Set RMS voltage     | Tolerance       |
|-------|---------------------|-----------------|
| 100   | 1.591 $\pm 0.0005$  | $\pm 1/2$ div.* |
| 30    | .895 $\pm 0.0005$   | $\pm 1/2$ div.* |
| 10    | .503 $\pm 0.0005$   | $\pm 1/2$ div.* |
| 3     | .283 $\pm 0.0005$   | $\pm 1/2$ div.* |
| .3    | .0895 $\pm 0.00005$ | $\pm 1$ div.*   |
| .1    | .0503 $\pm 0.00005$ | $\pm 1$ div.*   |

\* "Div." corresponds to a minor scale division on the applicable 4410A meter scale.

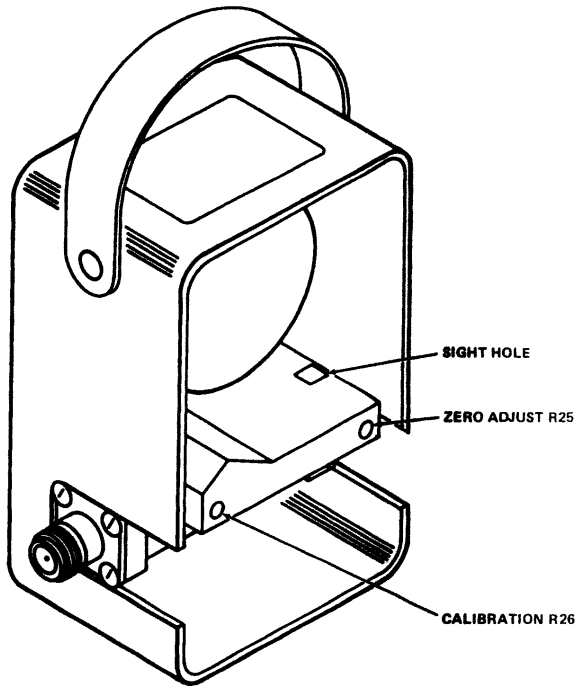

Figure 5-4. Calibration Potentiometers

b. **Test of Load Resistor. DC Resistance** - Check the condition of these load resistors by accurate measurement of the dc resistance between the inner and outer conductors of the RF input connector. Use a resistance bridge or ohmmeter with an accuracy of 1 percent or better at 50 ohms for this purpose. The measured resistance should be a nominal 50 ohms. It should not deviate by more than  $\pm 2$  ohms from this value.





## CHAPTER 6

## PREPARATION FOR RESHIPMENT

6-1. **PREPARATION FOR RESHIPMENT.** Before packing the test set for shipment, inspect the elements to ensure they are installed securely in their sockets. Check dust plug is locked in position on the wattmeter, and dust caps are on the RF connectors. Make sure the coaxial load resistor is fitted properly in the case, and dust caps are fitted on the variable frequency sampler and the UG201 connector. Ensure that the VSWR chart, instruction book, and both cables are fitted into the top of the case.

6-2. **STORAGE INSTRUCTIONS.** Store the test set in a cool, dry location. Keep the test set free of dust and dirt, and protect it from rough handling.



## CHAPTER 7

## PARTS LIST

7-1. GENERAL. This section lists, describes, and illustrates the component parts of the Model 4410-030 Test Set, manufactured by Bird Electronic Corporation, Cleveland (Solon), Ohio 44139.

7-2. PARTS ILLUSTRATION. Exploded views of the test set are provided in figures 7-1 and 7-2 to illustrate the component parts and their relation to each other. Parts on the illustrations are identified only by an index number. Cross reference from index number to part number is provided in the parts list.

7-3. PARTS LIST. The parts list contains a list of all procurable parts for the test set. If a defective part is not illustrated in figures 7-1 or 7-2 and is not listed in the parts list, it is not procurable separately, and the subassembly of which it is a part must be replaced.

7-4. EXPLANATION OF COLUMNS. The following paragraphs explain the information contained in the parts list.

a. The FIG. & INDEX NO. column lists the figure number of the illustration on which the part is located, and also gives the index number assigned to that part.

b. The BIRD PART NO. column contains Bird Electronic Corporation part numbers for all parts.

c. The DESCRIPTION column gives the name of the part, indented by columns to indicate relationship to the next higher assembly (NHA).

d. The MFR CODE column gives the vendor code of a part or subassembly not manufactured by Bird Electronic Corporation. Vendor code numbers correspond to the Federal Supply Code for Manufacturers (FSCM) as listed in Cataloging Handbook H4-1. Cross reference from vendor code to vendor's name and address is provided below.

| CODE  | NAME AND ADDRESS  |
|-------|---|
| 01121 | Allen Bradley Co.<br>1201 South 2nd St.<br>Milwaukee, WI 53204                |
| 15238 | ITT Semiconductors<br>500 Broadway<br>P.O. Box 1<br>Lawrence, MA 01841        |
| 18722 | RCA Corp.<br>Solid State Division<br>Crestwood Road<br>Mounting Top, PA 18707 |

| CODE  | NAME AND ADDRESS   |
|-------|--|
| 30010 | Vero Electronics<br>171 Bridge Rd.<br>Hauppauge, NY 11788  |
| 32293 | Intersil Inc.<br>10710 N. Tantau Ave.<br>Cupertino, CA 95014                                     |
| 50012 | Motorola Communications Group<br>Parts Division<br>1313 E. Algonquin Rd.<br>Schaumburg, IL 60196 |
| 56289 | Sprague Electric Co.<br>87 Marshall St.<br>North Adams, MA 01247                                 |
| 57771 | Stimpson Co., Inc.<br>900 Sylvan Ave.<br>Bayport, NJ 11705                                       |
| 58377 | National Capacitor Corp.<br>11731 Markon Dr.<br>Garden Grove, CA 92641                           |
| 59660 | Tusonix Inc.<br>2155 N. Forbes Blvd.<br>Suite 107<br>Tucson, AR 85745                            |
| 59880 | J.L. Thompson Rivet Company<br>Sawyer Road<br>Waltham, MA 02154                                  |
| 70485 | Atlantic India Rubber Works Inc.<br>571 W. Polk St.<br>Chicago, IL 60607                         |
| 70998 | Bird Electronic Corp.<br>30303 Aurora Rd.<br>Solon, OH 44139                                     |
| 71590 | Centralab Inc.<br>Hwy 20 W.<br>P.O. Box 858<br>Fort Dodge, IA 50501                              |
| 72982 | Murata Erie North American Inc.<br>645 W. 11th St.<br>Erie, PA 16512                             |

| CODE  | NAME AND ADDRESS   |
|-------|--|
| 73138 | Beckman Industrial Corp.<br>2500 Harbor Blvd.<br>Fullerton, CA 92634                                       |
| 78553 | Eaton Corp.<br>Engineered Fasteners Division<br>8700 Brookpark Rd.<br>P.O. Box 6688<br>Cleveland, OH 44101 |
| 79136 | Waldes Kohinoor Inc.<br>47-16 Austel Place<br>Long Island City, NY 11101                                   |
| 83907 | Accurate Rubber Products Co.<br>2647 N. Greenvlew Avenue<br>Chicago, IL 60614                              |
| 91637 | Dale Electronics Inc.<br>2064 12th Ave.<br>P.O. Box 609<br>Columbus, NE 68601                              |

e. The MFR PART NO. column contains part numbers of a part or subassembly not manufactured by Bird Electronic Corporation.

f. The UNITS PER ASSY column indicates the quantity of parts used in the illustrated application, but not necessarily the total quantity used in the unit.

g. The USABLE ON CODE column uses letter symbols to identify part variations between models. Since there is one model, the usable ON CODE column is blank.

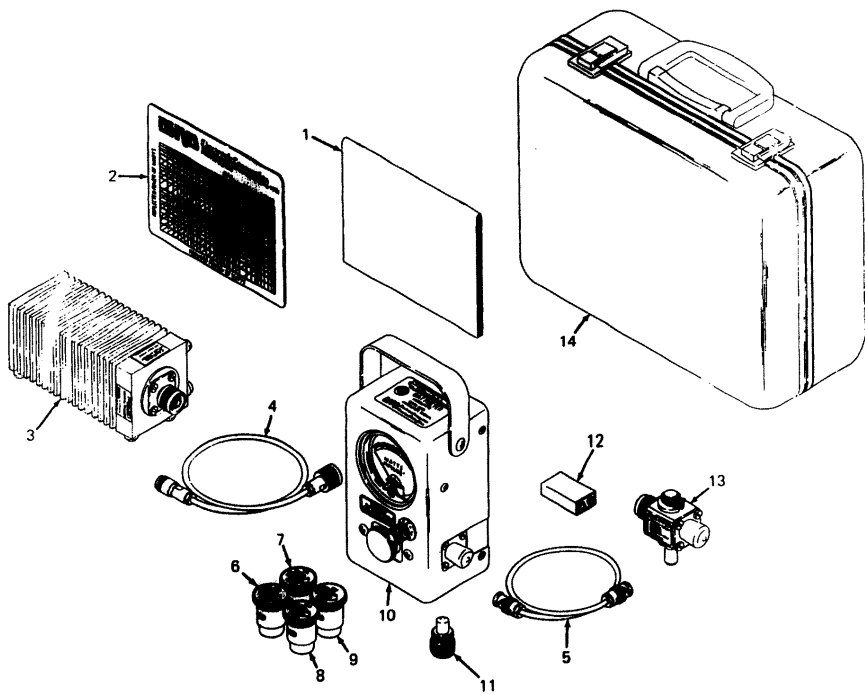

Figure 7-1. Test Set, Exploded View

| FIG. &<br>INDEX<br>NO. | BIRD<br>PART NO. | DESCRIPTION<br>1 2 3 4 5 6 7  | MFR<br>CODE | MFR<br>PART NO. | UNITS<br>PER<br>ASSY | USABLE<br>ON<br>CODE |
|------------------------|------------------|---|-------------|-----------------|----------------------|----------------------|
|                        |                  |   |             |                 |                      |                      |
| 7-1                    | 4410-030         | TEST SET . . . . .  |             |                 | 1                    |                      |
| -1                     |                  | . MANUAL, Instruction . . . . .                                       |             |                 | 1                    |                      |
| -2                     | 4400-012         | . VSWR CHART . . . . .  |             |                 | 1                    |                      |
| -3                     | 8164-040         | . TERMINAL LOAD RESISTOR . . . . .                                    |             |                 | 1                    |                      |
| -4                     | 4410-038-1       | . CABLE ASSEMBLY, . . . . .<br>RG 142B/U(1)                           |             |                 | 1                    |                      |
| -5                     | 4410-037-1       | . CABLE ASSEMBLY, . . . . .<br>RG 58/U(2)                             |             |                 | 1                    |                      |
| -6                     | 4410-3           | . ELEMENT, 1, 3, 10, 30, 100, .<br>300, and 1000 watts<br>2-30 MHz    |             |                 | 1                    |                      |
| -7                     | 4410-5           | . ELEMENT, 1, 3, 10, 30, 100, .<br>300, and 1000 watts<br>25-80 MHz   |             |                 | 1                    |                      |
| -8                     | 4410-6           | . ELEMENT, 1, 3, 10, 30, 100, .<br>300, and 1000 watts<br>50-200 MHz  |             |                 | 1                    |                      |
| -9                     | 4410-7           | . ELEMENT, 1, 3, 10, 30, 100, .<br>300, and 1000 watts<br>144-520 MHz |             |                 | 1                    |                      |
| -10                    | 4410A            | . WATTMETER (See figure 7-2) .  |             |                 | 1                    |                      |
| -11                    | 5-798-1          | . ADAPTER, Male N to female BNC .                                     |             |                 | 1                    |                      |
| -12                    | 5-1576           | . BATTERY, Lithium (spare) . . . . .                                  |             |                 | 1                    |                      |
| -13                    | 4275-020         | . SAMPLER ASSEMBLY, Variable . . . . .                                |             |                 | 1                    |                      |
| -14                    | 4300-071         | . CASE, Component . . . . .   |             |                 | 1                    |                      |



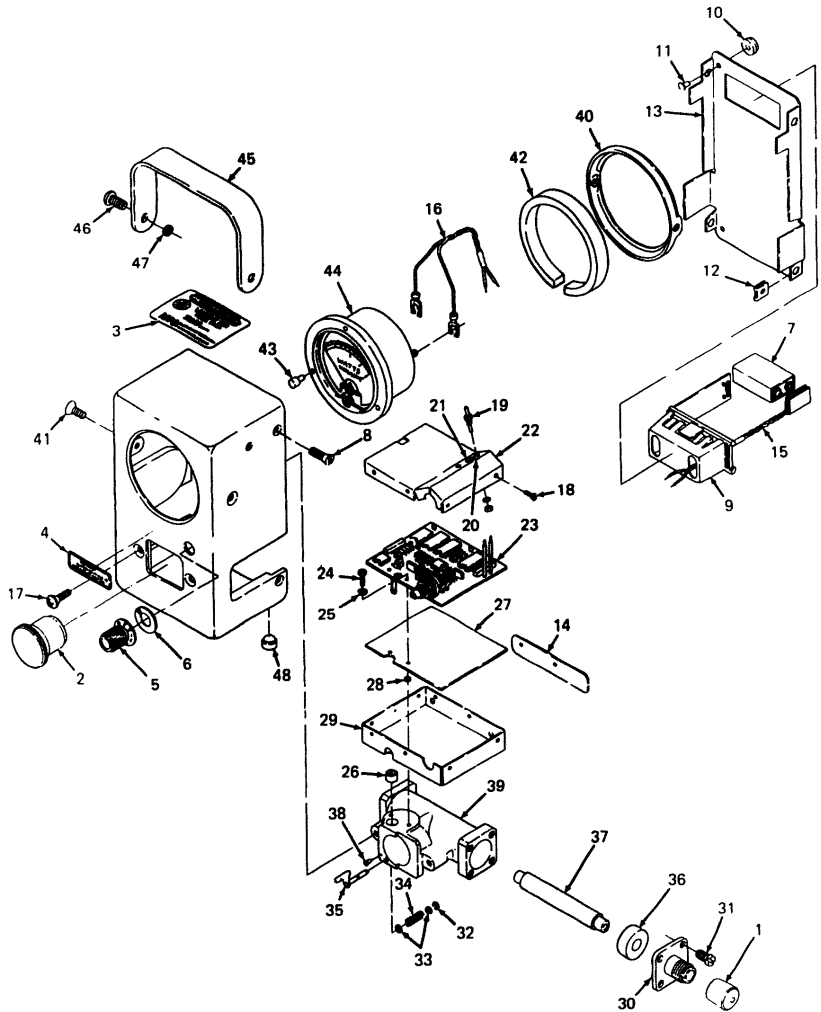

Figure 7-2. Wattmeter Assembly, Exploded View

| FIG. &<br>INDEX<br>NO. | BIRD<br>PART NO. | DESCRIPTION<br>1 2 3 4 5 6 7  | MFR<br>CODE | MFR<br>PART NO.        | UNITS<br>PER<br>ASSY | USABLE<br>ON<br>CODE |
|------------------------|------------------|---|-------------|------------------------|----------------------|----------------------|
|                        |                  |   |             |                        |                      |                      |
| 7-2                    | 4410-201         | WATTMETER ASSEMBLY . . . . .  |             |                        | REF                  |                      |
| -1                     | 701-19           | . CAP, Dust . . . . .   |             |                        | 2                    |                      |
| -2                     | 3610-031         | . PLUG, Dust . . . . .  |             |                        | 1                    |                      |
| -3                     | 4410-208         | . NAMEPLATE . . . . .   |             |                        | 1                    |                      |
| -4                     | 4410-013         | . LABEL, Factor . . . . .   |             |                        | 1                    |                      |
| -5                     | 4410-028         | . KNOB, Servicing . . . . .   |             |                        | 1                    |                      |
| -6                     | 4410-029         | . DECAL, Indicator . . . . .  |             |                        | 1                    |                      |
| -7                     | 5-1576           | . BATTERY, Lithium . . . . .  |             |                        | 1                    |                      |
|                        | 4410-039         | . COVER ASSEMBLY . . . . .<br>(ATTACHING PARTS)                                       |             |                        | 1                    |                      |
| -8                     | 4410-201-8       | . SCREW, Phillips flat hd, . .<br>no. 8-32 x 3/8 in. lg, sst<br>---*---               |             |                        | 4                    |                      |
| -9                     | 5-1567           | . . . HOLDER, Battery . . . . .   | 30010       | 75-2859C               | 1                    |                      |
| -10                    | 5-040            | . . . BUMPER, Foot . . . . .<br>(ATTACHING PARTS)                                     | 70485       | 1308W                  | 4                    |                      |
| -11                    | 01793-020        | . . . RIVET, Tubular, oval hd . .   | 59880       |                        | 4                    |                      |
| -12                    | 4410-039-2       | . . . NUT, Speed . . . . .  | 78553       | C-6452-<br>832-1       | 4                    |                      |
| -13                    | 4410-027         | . . . COVER, Housing . . . . .  |             |                        | 1                    |                      |
| -14                    | 4410-023         | . . . LABEL, Calibration . . . . .  |             |                        | 1                    |                      |
| -15                    | 4410-007         | . . . STRAP, Battery . . . . .  |             |                        | 1                    |                      |
| -16                    | 4410-006         | . . . WIRE, Meter . . . . .   |             |                        | 1                    |                      |
|                        | 4410-205         | . . . MODULE ASSEMBLY, Instru-<br>mentation<br>(ATTACHING PARTS)                      |             |                        | 1                    |                      |
| -17                    | 4410-201-5       | . SCREW, Phillips oval hd, . .<br>no. 10-32 x 1/2 in. lg, sst<br>---*---              |             |                        | 2                    |                      |
|                        | 4410-020         | . . . TOP, Box, RFI shield . . . .<br>(ATTACHING PARTS)                               |             |                        | 1                    |                      |
| -18                    | 4410-205-10      | . . . SCREW, Self-tapping, pan .<br>hd, type B, no.<br>2 x 1/8 in. lg, sst<br>---*--- |             |                        | 9                    |                      |
| -19                    | 5-1528-1         | . . . CAPACITOR, Feed-thru, . .<br>threaded, with nut<br>and lockwasher               | 59660       | 2495-003-<br>X550-102M | 2                    |                      |
| -20                    | 5-640            | . . . LUG, Solder . . . . .<br>(ATTACHING PART)                                       |             |                        | 1                    |                      |
| -21                    | 5-256-1          | . . . RIVET, Tubular, 1/8 x . .<br>1/8 in. lg, brass<br>---*---                       |             |                        | 1                    |                      |

| FIG. & INDEX NO. | BIRD PART NO. | DESCRIPTION<br>1 2 3 4 5 6 7   | MFR   | MFR      | UNITS PER ASSY | USABLE ON CODE |
|------------------|---------------|--|-------|----------|----------------|----------------|
|                  |               |  | CODE  | PART NO. |                |                |
| 7-2-22           | 4410-019      | . . . TOP, Box . . . . .   |       |          | 1              |                |
| -23              | 4410-203      | . . . BOARD ASSEMBLY, Printed . . .<br>circuit (See figure 7-3)<br>(ATTACHING PARTS) |       |          | 1              |                |
| -24              | 4410-205-7    | . . . SCREW, Pan head, no. 4-40 . . .<br>x 5/16 in. lg, sst                          |       |          | 2              |                |
| -25              | 4410-205-8    | . . . WASHER, Lock, internal . . .<br>tooth, no. 4, sst<br>---*---                   |       |          | 2              |                |
| -26              | 4391-026      | . . . BEAD, Keying . . . . .   |       |          | 1              |                |
| -27              | 4410-016      | . . . INSULATOR, Fish paper . . .  |       |          | 1              |                |
| -28              | 4391-027      | . . . SPACER . . . . .   |       |          | 2              |                |
| -29              | 4410-018      | . . . BOTTOM, Box . . . . .  |       |          | 1              |                |
|                  | 4410-004      | . . . LINE SECTION ASSEMBLY . . .  |       |          | 1              |                |
| -30              | 4240-062      | . . . CONNECTOR ASSEMBLY, . . .<br>Female N<br>(ATTACHING PARTS)                     |       |          | 2              |                |
| -31              | 4410-004-3    | . . . SCREW, Pan hd, slotted, . . .<br>no. 8-32 x 1/4 in.<br>lg, sst<br>---*---      |       |          | 8              |                |
|                  | 4230-006-2    | . . . LINE SECTION ASSEMBLY . . .  |       |          | 1              |                |
| -32              | 4230-006-8    | . . . RING, Retaining . . . . .  | 79136 | 5133-9   | 1              |                |
| -33              | 4230-075      | . . . . . WASHER, Pin, pivot . . . . .   |       |          | 2              |                |
| -34              | 4230-074      | . . . . . SPRING, Latch . . . . .  |       |          | 1              |                |
| -35              | 4230-070      | . . . . . LATCH AND PIVOT PIN . . .<br>ASSEMBLY                                      |       |          | 1              |                |
| -36              | 4230-007      | . . . . . INSULATOR . . . . .  |       |          | 2              |                |
| -37              | 4230-008      | . . . . . ROD, Connector . . . . .   |       |          | 1              |                |
|                  | 4230-047      | . . . . . LINE SECTION AND PIN . . .<br>ASSEMBLY                                     |       |          | 1              |                |
| -38              | 4230-073      | . . . . . PIN, Stop latch . . . . .  |       |          | 1              |                |
| -39              | 4230-009-1    | . . . . . SECTION, Line . . . . .  |       |          | 1              |                |
|                  | 4410-202      | . . . HOUSING AND METER ASSEMBLY . . .   |       |          | 1              |                |
| -40              | 4420-087      | . . . MOUNT, Shock . . . . .<br>(ATTACHING PARTS)                                    |       |          | 1              |                |
| -41              | 4410-202-6    | . . . SCREW, Phillips oval hd, . . .<br>no. 10-32 x 1/2 in. lg,<br>sst<br>---*---    |       |          | 2              |                |
| -42              | 5-1066        | . . . STRIP, Shock . . . . .   |       |          | 1              |                |
| -43              | 4220-098      | . . . BUMPER, Stem . . . . .   |       |          | 3              |                |
| -44              | 2080-066      | . . . METER . . . . .  |       |          | 1              |                |

| FIG. &<br>INDEX<br>NO. | BIRD<br>PART NO. | DESCRIPTION               |   |   |   |   |   |       | MFR<br>CODE | MFR<br>PART NO. | UNITS<br>PER<br>ASSY | USABLE<br>ON<br>CODE |
|------------------------|------------------|---------------------------|---|---|---|---|---|-------|-------------|-----------------|----------------------|----------------------|
|                        |                  | 1                         | 2 | 3 | 4 | 5 | 6 | 7     |             |                 |                      |                      |
| 7-2-                   | 4410-003         | . .                       |   |   |   |   |   |       |             |                 | 1                    |                      |
| -45                    | 8580-003         | . . .                     |   |   |   |   |   |       |             |                 | 1                    |                      |
|                        |                  | (ATTACHING PARTS)         |   |   |   |   |   |       |             |                 |                      |                      |
| -46                    | 4410-003-6       | . . .                     |   |   |   |   |   |       |             |                 | 2                    |                      |
|                        |                  | SCREW, Phillips truss . . |   |   |   |   |   |       |             |                 |                      |                      |
|                        |                  | hd, no. 10-32 x 1/2       |   |   |   |   |   |       |             |                 |                      |                      |
|                        |                  | in. lg, sst               |   |   |   |   |   |       |             |                 |                      |                      |
| -47                    | 8240-054         | . . .                     |   |   |   |   |   |       |             |                 | 2                    |                      |
|                        |                  | WASHER, Strap screw . . . |   |   |   |   |   |       |             |                 |                      |                      |
|                        |                  | -----                     |   |   |   |   |   |       |             |                 |                      |                      |
| -48                    | 5-1388           | . . .                     |   |   |   |   |   | 83907 | 9600-305    |                 | 4                    |                      |
| -49                    | 4410-009         | . . .                     |   |   |   |   |   |       |             |                 | 1                    |                      |
|                        |                  | HOUSING . . . . .         |   |   |   |   |   |       |             |                 |                      |                      |

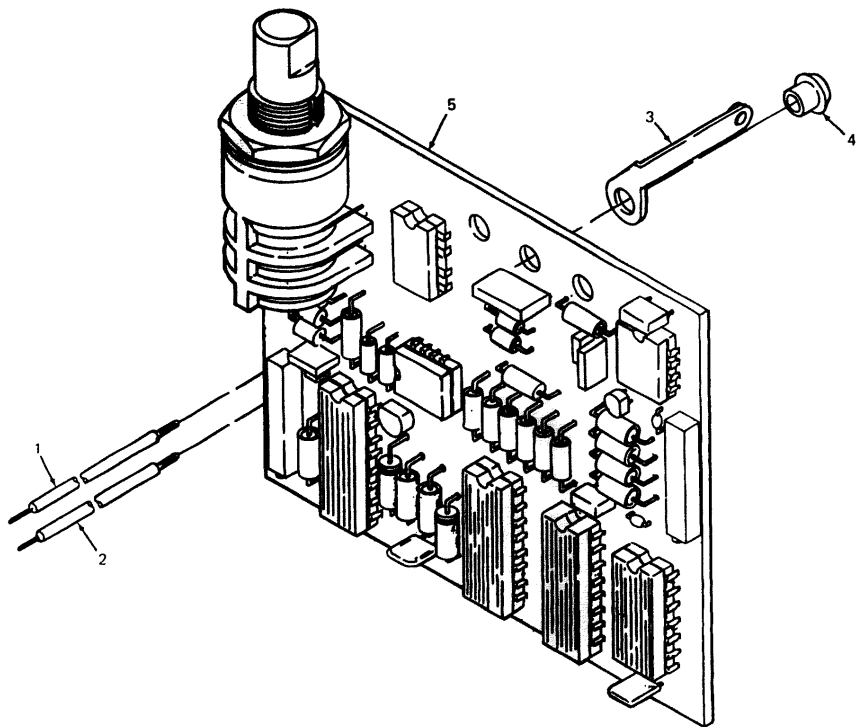
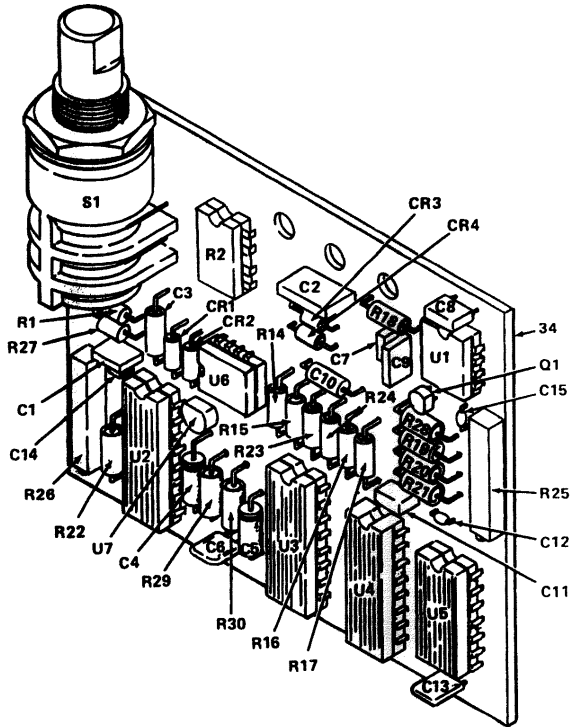

Figure 7-3. Printed Circuit Board Assembly, Exploded View

| FIG. &<br>INDEX<br>NO. | BIRD<br>PART NO. | DESCRIPTION  |   |   |   |   |   |   | MFR<br>CODE | MFR<br>PART NO. | UNITS<br>PER<br>ASSY | USABLE<br>ON<br>CODE |   |  |
|------------------------|------------------|--|---|---|---|---|---|---|-------------|-----------------|----------------------|----------------------|---|--|
|                        |                  | 1  | 2 | 3 | 4 | 5 | 6 | 7 |             |                 |                      |                      |   |  |
| 7-3                    | 4410-203         | BOARD ASSEMBLY, Printed . . . . .<br>circuit                           |   |   |   |   |   |   | 57771       | GS 5-5          | REF                  |                      |   |  |
| -1                     | 4510-005-7       | . WIRE, Hook up, red, 3 in. . . . .<br>1g                              |   |   |   |   |   |   |             |                 |                      |                      | 1 |  |
| -2                     | 4510-005-8       | . WIRE, Hook up, orange, . . . . .<br>3 in. 1g                         |   |   |   |   |   |   |             |                 |                      |                      | 1 |  |
| -3                     | 4381-007         | . SPRING CONTACT ASSEMBLY . . . . .<br>(ATTACHING PARTS)               |   |   |   |   |   |   |             |                 |                      |                      | 1 |  |
| -4                     | 5-1224-1         | . EYELET . . . . .<br>---*---  |   |   |   |   |   |   |             |                 |                      |                      | 1 |  |
| -5                     | 4410-204         | . BOARD, Printed circuit, . . . . .<br>subassembly (see figure<br>7-4) |   |   |   |   |   |   |             |                 | 1                    |                      |   |  |



| REF DES | ITEM NO. | REF DES | ITEM NO. | REF DES | ITEM NO. |
|---------|----------|---------|----------|---------|----------|
| CR1     | 1        | C13     | 6        | R24     | 21       |
| CR2     | 1        | C14     | 6        | R25     | 22       |
| CR3     | 1        | C15     | 9        | R26     | 22       |
| CR4     | 1        | Q1      | 10       | R27     | 23       |
| C1      | 2        | R1      | 11       | R28     | 24       |
| C2      | 3        | R2      | 12       | R29     | 25       |
| C3      | 4        | R14     | 13       | R30     | 26       |
| C4      | 4        | R15     | 14       | S1      | 27       |
| C5      | 5        | R16     | 15       | U1      | 28       |
| C6      | 6        | R17     | 16       | U2      | 29       |
| C7      | 7        | R18     | 17       | U3      | 29       |
| C8      | 7        | R19     | 17       | U4      | 30       |
| C9      | 8        | R20     | 18       | U6      | 31       |
| C10     | 5        | R21     | 18       | U8      | 32       |
| C11     | 6        | R22     | 19       | U7      | 33       |
| C12     | 9        | R23     | 20       |         |          |

Figure 7-4. Printed Circuit Board Subassembly, Exploded View

| FIG. &<br>INDEX<br>NO. | BIRD<br>PART NO. | DESCRIPTION  | MFR<br>CODE | MFR<br>PART NO.      | UNITS<br>PER<br>ASSY | USABLE<br>ON<br>CODE |
|------------------------|------------------|--|-------------|----------------------|----------------------|----------------------|
|                        |                  |  |             |                      |                      |                      |
| 7-4                    | 4410-204         | BOARD, Printed circuit, . . . . .<br>subassembly       |             |                      | REF                  |                      |
| -1                     | 5-1225           | . DIODE . . . . .                                      | 15238       | 1N4148               | 4                    |                      |
| -2                     | 5-1524           | . CAPACITOR, 0.1 microfarad, . . . . .<br>100 vdc, 10% | 57771       | GS 5-5               | 1                    |                      |
| -3                     | 5-1527           | . CAPACITOR, 0.047 micro- . . . . .<br>farad, 250 vdc  |             |                      | 1                    |                      |
| -4                     | 5-1091-2         | . CAPACITOR, 2.2 microfarad, . . . . .<br>15 vdc, 10%  | 56289       | 150D225X<br>9015A2   | 2                    |                      |
| -5                     | 5-1091-1         | . CAPACITOR, 1.0 microfarad, . . . . .<br>15 vdc, 10%  | 56289       | 150D105X<br>9015A2   | 2                    |                      |
| -6                     | 5-688-8          | . CAPACITOR, Red cap, 0.1 . . . . .<br>microfarad      | 72982       | RPE121Z5U<br>104M50V | 4                    |                      |
| -7                     | 5-1525           | . CAPACITOR, 100 picofared, . . . . .<br>200 vdc       |             |                      | 2                    |                      |
| -8                     | 5-1526           | . CAPACITOR, 100 picofared, . . . . .<br>160 vdc, 5%   |             |                      | 1                    |                      |
| -9                     | 5-1146-1         | . CAPACITOR, 100 picofared, . . . . .<br>100 vdc       | 71590       | CN15A101K            | 2                    |                      |
| -10                    | 5-1089           | . TRANSISTOR . . . . .                                 |             |                      | 1                    |                      |
| -11                    | 5-157            | . RESISTOR, 30 K ohm, 1/8 . . . . .<br>watt            | 91637       | RN55D-<br>3005-F     | 1                    |                      |
| -12                    | 4410-024         | . RESISTOR, Network . . . . .                          | 73138       | 1694-19-0            | 1                    |                      |
| -13                    | 5-157            | . RESISTOR, 4.02 K ohm, 1/8 . . . . .<br>watt          | 91637       | RN55D-<br>4024-F     | 1                    |                      |
| -14                    | 5-157            | . RESISTOR, 9.76 K ohm, 1/8 . . . . .<br>watt          | 91637       | RN55D-<br>9764-F     | 1                    |                      |
| -15                    | 5-157            | . RESISTOR, 28.7 K ohm, 1/8 . . . . .<br>watt          | 91637       | RN55D-<br>2875-F     | 1                    |                      |
| -16                    | 5-157            | . RESISTOR, 6.19 K ohm, 1/8 . . . . .<br>watt          | 91637       | RN55D-<br>6194-F     | 1                    |                      |
| -17                    | 5-955-19         | . RESISTOR, 1.0 M ohm, 5% . . . . .                    |             |                      | 2                    |                      |
| -18                    | 5-157            | . RESISTOR, 10.0 K ohm, 1/8 . . . . .<br>watt          | 91637       | RN55D-<br>1005-F     | 2                    |                      |
| -19                    | 5-157            | . RESISTOR, 100 K ohm, 1/8 . . . . .<br>watt           | 91637       | RN55D-<br>1006-F     | 1                    |                      |
| -20                    | 5-157            | . RESISTOR, 4.64 K ohm, 1/8 . . . . .<br>watt          | 91637       | RN55D-<br>4644-F     | 1                    |                      |
| -21                    | 5-157            | . RESISTOR, 3.74 K ohm, 1/8 . . . . .<br>watt          | 91637       | RN55D-<br>3744-F     | 1                    |                      |
| -22                    | 5-1575-1         | . TRIMPOT, 200 K ohm . . . . .                         | 01121       | 94P204               | 2                    |                      |
| -23                    | 5-546-37         | . RESISTOR, 750 ohm . . . . .                          |             |                      | 1                    |                      |
| -24                    | 5-157            | . RESISTOR, 1 K ohm, 1/8 . . . . .<br>watt             | 91637       | RN55D-<br>1004-F     | 1                    |                      |



| FIG. &<br>INDEX<br>NO. | BIRD<br>PART NO. | DESCRIPTION<br>1 2 3 4 5 6 7                            | MFR<br>CODE | MFR<br>PART NO.  | UNITS<br>PER<br>ASSY | USABLE<br>ON<br>CODE |
|------------------------|------------------|---|-------------|------------------|----------------------|----------------------|
|                        |                  |   |             |                  |                      |                      |
| 7-4-25                 | 5-157            | . RESISTOR, 27.4 K ohm, 1/8 . .<br>watt                 | 91637       | RN55D-<br>2745-F | 1                    |                      |
| -26                    | 5-157            | . RESISTOR, 4.99 K ohm, 1/8 . .<br>watt                 | 91637       | RN55D-<br>4994-F | 1                    |                      |
| -27                    | 4410-008         | . SWITCH, Rotary, servicing . .                         |             |                  | 1                    |                      |
| -28                    | 5-1226           | . INTEGRATED CIRCUIT, Linear, .<br>CMOS                 | 18722       | CA3130AE         | 1                    |                      |
| -29                    | 5-1366           | . INTEGRATED CIRCUIT, Triple .<br>2 channel, analog MUX | 58377       | 4053B            | 2                    |                      |
| -30                    | 5-1368           | . INTEGRATED CIRCUIT, Dual . .<br>4 bit shift register  | 50012       | 4015B            | 1                    |                      |
| -31                    | 5-1369           | . INTEGRATED CIRCUIT, Hex . . .<br>Schmitt inverter     | 50012       | 4584B            | 1                    |                      |
| -32                    | 5-1331           | . INTEGRATED CIRCUIT, CMOS, . .<br>voltage converter    | 32293       | 1CL7660<br>CPA   | 1                    |                      |
| -33                    | 5-1523           | . INTEGRATED CIRCUIT, Voltage .<br>regulator            | 50012       | LM317LZ          | 1                    |                      |
| -34                    | 4410-206         | . BOARD, Printed circuit . . .                          |             |                  | 1                    |                      |